



AIRTIGHT S200 Filtration System

FEATURES

- The *most powerful* filter of its size on the market
- *High efficiency fan* (self cleaning) –
- *Quiet, powerful operation*
- Reverse incline impeller
- Competitively priced
- Outdoor versions available

SPECIFICATIONS

Model	AIRTIGHT S200 2.2kw
Cleaning	Constant bag flush
Capacity	2,500 m ³ /h @ 1,800 Pa (3000rpm)
Filter Area	8 x Needlefelt filter bags ~ 8 m ² filter area
Fan	- High efficiency, materials handling fan, heavy duty plate - Self cleaning Reverse incline impeller Duct inlet: 200mm
Motor	High efficiency 2.2KW, 2980 rpm
Motor Starter	Motor Start/Stop Box included
Dimensions	~1,150 (D) x 1,900 W x 3,250 H

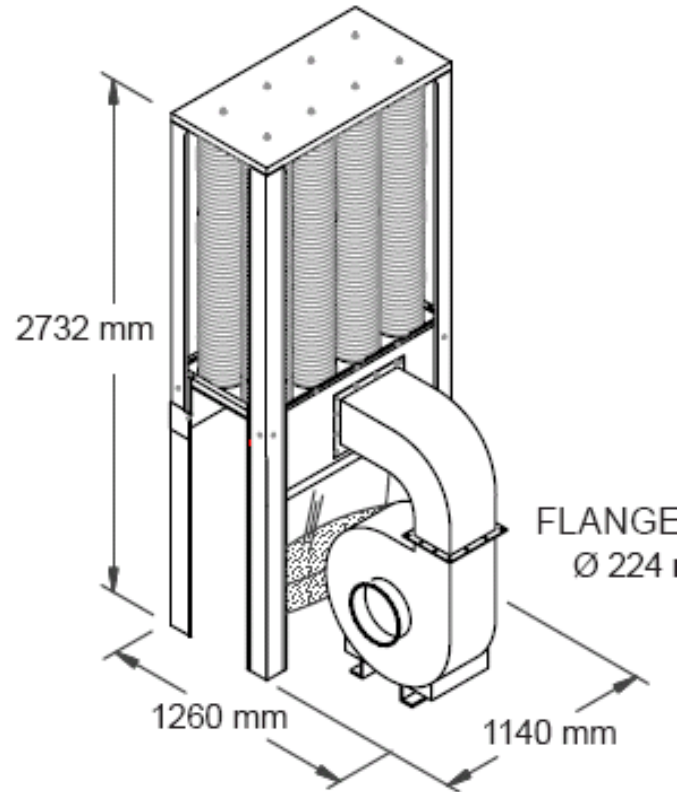

Performance Curve

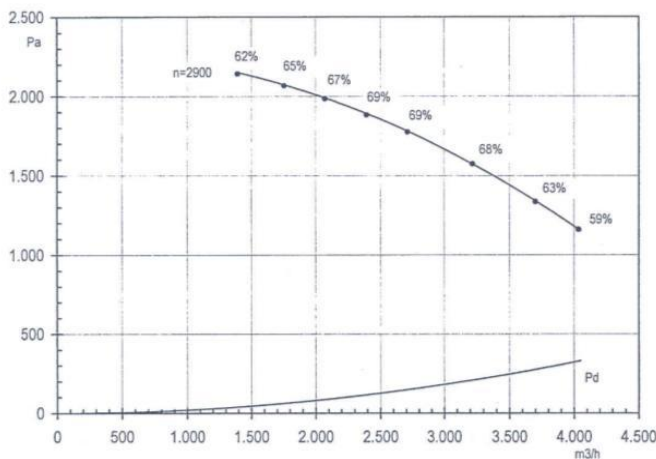

The S200 filter is typically used for

- Small CNC machines (low volume/low waste load)
- Panel Saws + Small edge banders and/or
- Multiple smaller machines running simultaneously

Why choose the Airtight S200 filter system?

- Proven, reliable & powerful performance

